

# Heathkit Audio Generator Model AG-9A

BY JOHN VUOLO



When I first got started in the radio collecting hobby I realized early on that I would need test equipment. As funds were limited I began to go to a local radio swap meet that I heard about held on Sundays. There I met other enthusiasts like me, and I made some ham radio friends. They saw my interest in the hobby and one of them was kind enough to give me a Heathkit AG9-A Audio Generator. It was a spare for him and it wasn't working anyway, so he passed it on to me along with the manual. I took my prize in hand and went home to read the book and tear down the unit to see what I needed to do to get it back to operational.

The Heathkit AG-9A Audio Generator is a simple, yet versatile instrument. It provides ease of operation in a multitude of test setups encountered in audio work. The wide range of repeatable frequencies and the metered low distortion output voltages, covering nearly all values encountered in audio work, contained in the conveniently small cabinet meant this instrument would have a preferred spot on my workbench—once I got it going.

## FIXING THE AG-9A

The first repair I made to the AG-9A was in the power supply. It uses the conventional power transformer full-wave rectifier circuit feeding a ripple filter consisting of two capacitors and a choke. I found that I had to replace the 6X4 tube

as well as the dual 40- $\mu$ f capacitors in the power supply. That brought the voltages back up. I also had to replace the pilot lamp.

The oscillator uses a 6AU6 pentode voltage amplifier and a 6CL6 triode-connected cathode follower. Regenerative feedback from the 6CL6 to the 6AU6 cathode is applied through the tungsten filament candelabra-based lamp. A filament check of the lamp indicated it was still good. I had tested the 6CL6 and 6AU6 tubes on a friend's TV7 tester and found them to be good as well.

Degenerative feedback is applied from the 6CL6 through a "notch" network to the grid of the 6AU6. The resultant oscillation occurs at the "notch" frequency, where degeneration is minimal and phase shift is zero. The notch network is a capacitor-shunted bridged-T type. I found that the C1 and C2 values had gone up in the X1 and X10 settings, so I replaced them. The amplitude of oscillation is maintained at a nearly constant value by the tungsten lamp. The regenerative feedback is applied through a voltage divider consisting of the lamp and the "oscillator" control. An increase in output signal increases the lamp current, the lamp temperature and the lamp resistance. This reduces the amount of feedback applied to the 6AU6 cathode and the resultant output. A balanced condition is thus obtained. The oscillator control is used to set the nominal output level.

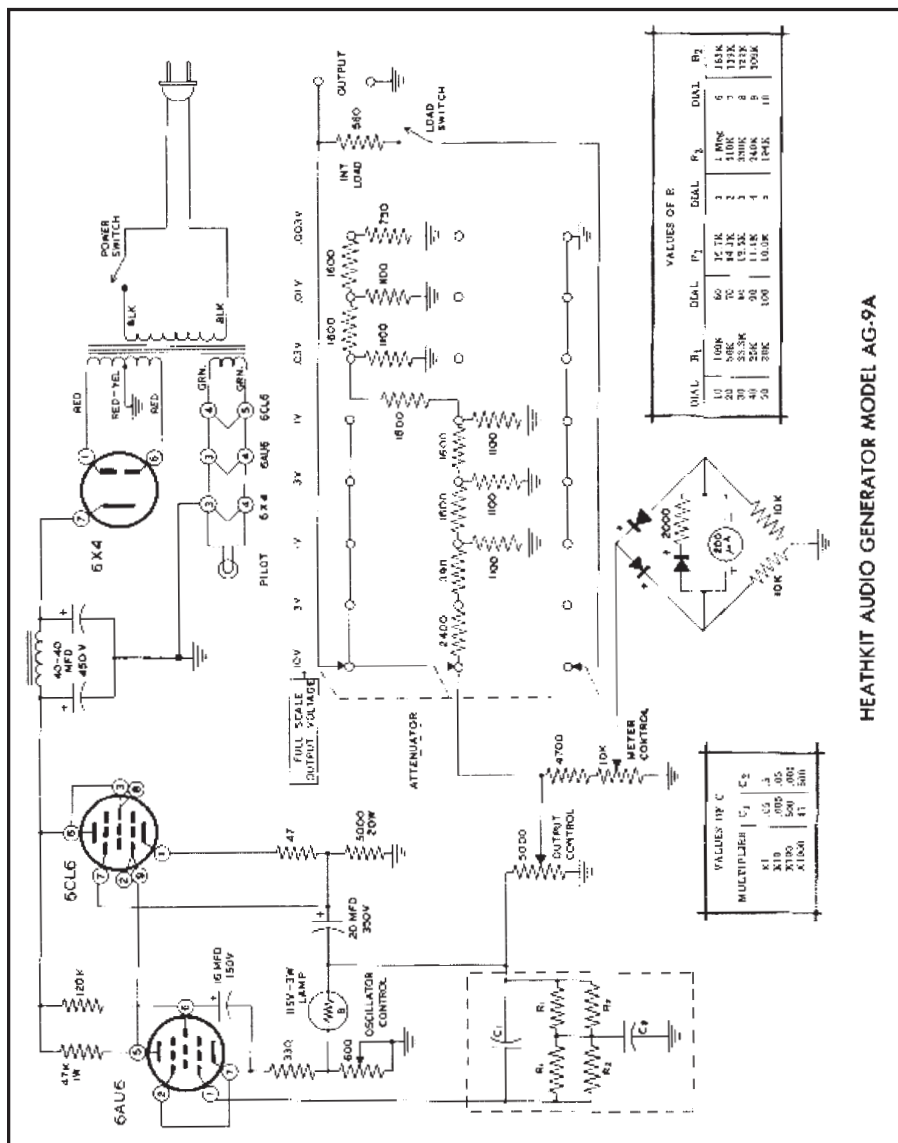

HEATHKIT AUDIO GENERATOR MODEL AG-9A

The notch network consists basically of two resistors and two capacitors. From the relationship shown it is evident that a decrease in capacities by a factor of 10 will increase the frequency by a factor of 10. As the values of C1 and C2 were chosen with a 10:1 ratio, five capacitors can do the job of four pair or eight in achieving four decade ranges.

The attenuator reduces the output voltage from the 6CL6 cathode-follower through a continuously variable 5000-ohm "output" control, and then through a step attenuator. The attenuator system is designed for 600-ohm output up

through 1 volt and high-impedance output at the 3- and 10-volt positions. The 600-ohm positions may be terminated by an internal load for high-impedance work, or this load may be disconnected when an external 600-ohm load is used. In the 3- and 10-volt positions, the internal load is automatically disconnected. The attenuator operates in steps of 10 dB.

The metering circuit measures the voltage at the arm of the output control. A portion of this voltage, determined by the "meter" control, is rectified by a half bridge using crystal diodes. Non-linearity of the diodes at low signal level is

compensated by a third diode across the meter. The meter carries three scales: 0–10 volt, 0–3 volt, and -10+2 dB. When the instrument is operated with the proper termination, the meter and attenuator will indicate the output level at the binding posts.

I found that both crystal diodes had to be replaced. I also tested all the resistor and capacitor values and replaced any out-of-tolerance ones I found. Fortunately at the time I was able to get the needed parts from Heathkit. I don't remember now what I paid for them, but it had to be \$10 or less.

After making these repairs and giving the AG-9A a thorough cleaning it was time to test it out.

### PUTTING IT THROUGH ITS PACES

I brought the AG-9A over to my friend's place and we used his Oscilloscope to check it out. I used the AG-9A for years but retired it some two decades ago for better equipment. I recently brought it back out of mothballs, however, and found that it's still about as accurate today as I remember it was back then. Over the years I've repaired one or two other AG-9As for friends who, for various reasons, didn't want to take on the repair themselves. Some of the parts are harder to come by, but with a little searching and ingenuity you, too, can still repair one.

*John Vuolo, e-mail: [jvulo19603@aol.com](mailto:jvulo19603@aol.com)*

*John has been working in the telecommunications industry for 34 years. He has been restoring and collecting antique radios, tube amplifiers and receivers, TVs, phonographs, and reel-to-reel machines for 40 years.*

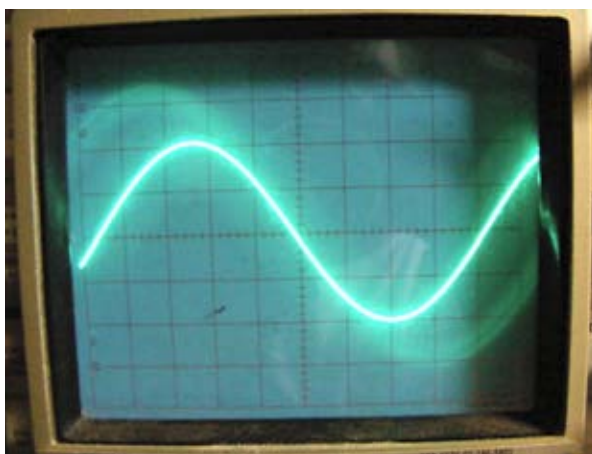
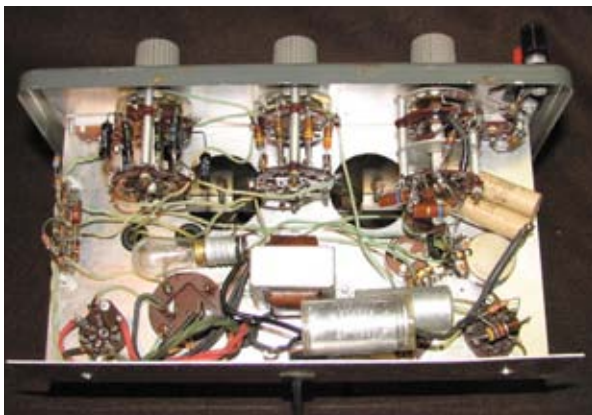

*Top: Top view of the AG-9A  
Middle: Bottom view of the AG-9A  
Bottom: Oscilloscope pattern*